

Massey Ferguson	Engine No.	Cylinder			Piston			
	A4.203	Cyl.	Bore mm	Length mm	Pin Ø mm	Length mm	No. of Rings	Piston Type
		4	91.49	215.9	31.75	108.04	5	

Applications: 65, 765

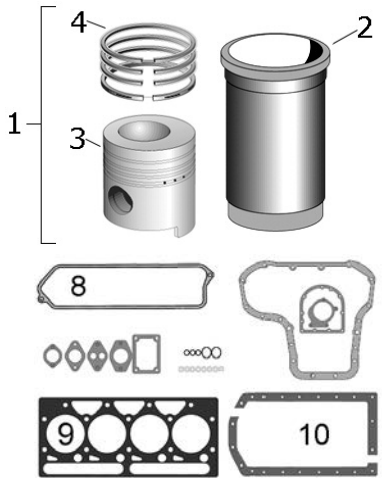

	Description	Notes	OEM Ref:	
1	Piston, Ring & Liner Kit		U5MK0064, 3639471M1, U5MK0064	S.40444
2	Liner		732638M1, 31358308	S.40431
3	Piston		734460M91, 81512	S.40403
4	Piston Ring Set		745819M91, 41158058, P4017	S.40416
1	Piston, Ring & Liner Kit		82116	S.40445
2	Liner		734179M1, 31358345	S.40432
3	Piston		734460M91, 81512	S.40403
4	Piston Ring Set		836325M91	S.40417
	Head Gasket Set	Supercedes S.48004	746051M91, 69036	S.40591
7	Bottom Gasket Set		735772M91, 743029M91, 68016, 83373	S.40607
8	Rocker Cover Gasket		731164M1, 0490704	S.40632
9	Head Gasket		731011M2, 36812125	S.40622
10				

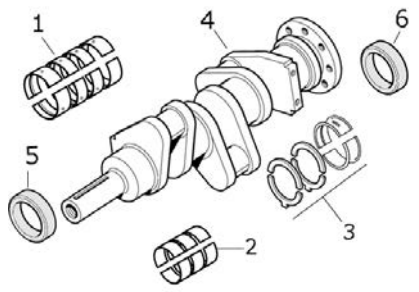

	Main Bearings Set (Std.)		745405M91 68082	S.40335
1	Main Bearings Set +0.010"		745406M91 68082A	S.40336
	Main Bearings Set +0.020"		745407M91 68082B	S.40337
	Main Bearings Set +0.030"		745408M91 68082C	S.40338
2	Conrod Bearings Set (Std.)		737066M91 85035	S.40319
	Conrod Bearings Set +0.010"		737067M91 85035A	S.40320
	Conrod Bearings Set +0.020"		737068M91 85035B	S.40321
	Conrod Bearings Set +0.030"		737069M91 85035C	S.40322
3	Thrust Bearings Set		735112/3M1 3113721 1/21	S.40343
	Thrust Bearings Set +0.075"		735800/1M1 31137212/22	S.40344
4	Crankshaft 4.192 / 4.203	Rope Seal	3638473M91, 742742M91, U5BG0028,	S.40310
	Flywheel Lock Tab		731192M1, 0921062	S.40347
	Ring Gear	115T	4222485M1+, 3637030M1, 32762145+, 33221328, 3408357M1, 731008M1, 410236	S.40364
5	Oil Seal	2.25" x 3.0" x 0.375" Viton	1447689M1, 2415344	S.40352
6	Rope Seal Set 2pcs		735866M1, 36883106	S.40354